

# INSTALLATION, OPERATION AND MAINTENANCE MANUAL

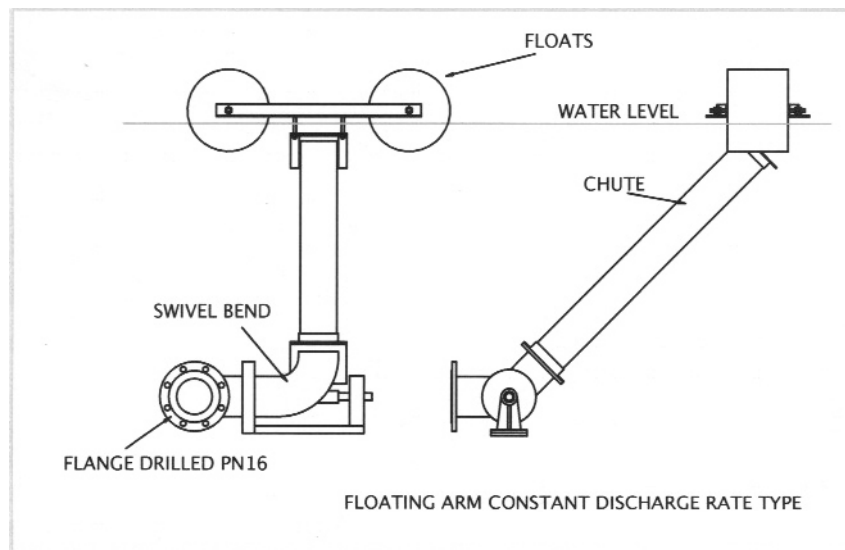

## FLOATING ARM

# WATERFRONT

We are a Glasgow based company providing water engineering solutions in fluid control for both the UK and International markets.



Waterfront Engineering Services Ltd was formed in 1988 specialising in the installation and commissioning of Penstocks for Treatment Plants.

We offer a service to supply, refurbish and install valves, penstocks and ancillary equipment.

We have extended our range to incorporate a wide range of products for controlling Water Flows. These products cover all types of valves, penstocks and ancillary products.

Waterfront Engineering Services LTD provides consistent high quality products and services.

CONTENTS :

INSTALLATION PAGE 4

ADJUSTMENT PAGE 5

MAINTENANCE PAGE 6

DRAWING FFP8902-ASS 1 PAGE 7

DRAWING FVS8902-ASS 1 PAGE 8

## INSTALLATION RECOMMENDATIONS

1. On receipt of the floating arm position the Mounting Plate (see DrgFFP8902-ASS1) in the correct position on the base of the chamber and drill holes into the concrete to suit the fixing bolt size. Insert the fixing bolts and bed the mounting plate level and in the correct position on 25 mm of grout and pinch the fixing bolts.
  2. After the Grout has hardened, fully tighten the fixing bolts.
  3. Connect the outlet pipe (supplied by others) to the swivel bend with a suitable gasket and grout into the previously prepared hole in the adjacent weir wall.
  4. After the grout has hardened attached the floating arm chute (DrgFFP8902-ASS1) to the swivel bend ensuring that the float frame is supported.
- NOTE:
- The float support blocks in the chamber (supplied by others) **MUST BE FIXED** such that the **FLOATS** or **FLOAT FRAME** is supported.
5. Check that the Swivel Bend and Float Frame are free to move.
  6. The chamber can now be filled with water.

## ADJUSTMENTS

1. The Orifice Plate must be set at 100mm below the Water line to achieve the constant flow rate. This is achieved by adjustment of the lifting screws. (DRG FVS8902-ASS 1). Undo both bottom lifting screw nuts and adjust the lifting screw top nuts by an equal number of turns to achieve the 100mm setting position. Retighten the bottom nuts.

2. Although the floating level has been calculated, the exact weights of all the components will in practice differ hence some adjustment to the floating level of the arm may be required in practice. The calculated level of the Float Frame should be 10mm approximately above water line.

If this is SUBSTANTIALLY different the floating level can be adjusted by adding Weights or Floats to the screwed ends of the float shaft as required on site.

### NOTES:

The position of the floats on the water surface cannot be determined precisely from theory and must be finalised during installation.

The weight of the floats below the water surface MUST be greater than the weight of the floats above the water for the floats to be STABLE.

This means in practice that the centreline of the float MUST be below the water surface.

To achieve this condition if the centreline of the float is above the water surface level, additional weights must be added to the floating arm.

There are 2 points at which the weights can be added.

- a. On the ends of the 4 float studs provided
- b. On the float carriage bolted to the connecting threaded rod.

These weights can be provided with the floating arm if necessary.

Please contact Waterfront and state the floating position of the float centreline above the water surface in order that the correct weights can be calculated and provided for the installation.

## MAINTENANCE

1. Should there be a build up of scum around the Scum Box, then this should be cleaned off periodically using a water jet spray.

2. If after a period of time depending on the scum levels or floating debris in the chamber the floating arm has changed its position compared to the water level, check that the swivel bend is free to move and is not contaminated by any debris.

If necessary use a water jet spray.

3. If after a period of time depending on the scum levels or floating debris in the chamber the floats have changed their position and are lying at an angle compared to the water level, check that the rod ends bearings are free to move and are not contaminated with debris from the chamber.

If necessary use a water jet spray.

4. Check annually that all fixings are secure and that all the moving parts (Swivel Bend and Rod End Bearings) are moving freely.

5. Check annually that the Orifice Plate has not been damaged by debris.

## DRAWING FFP8902-ASS 1

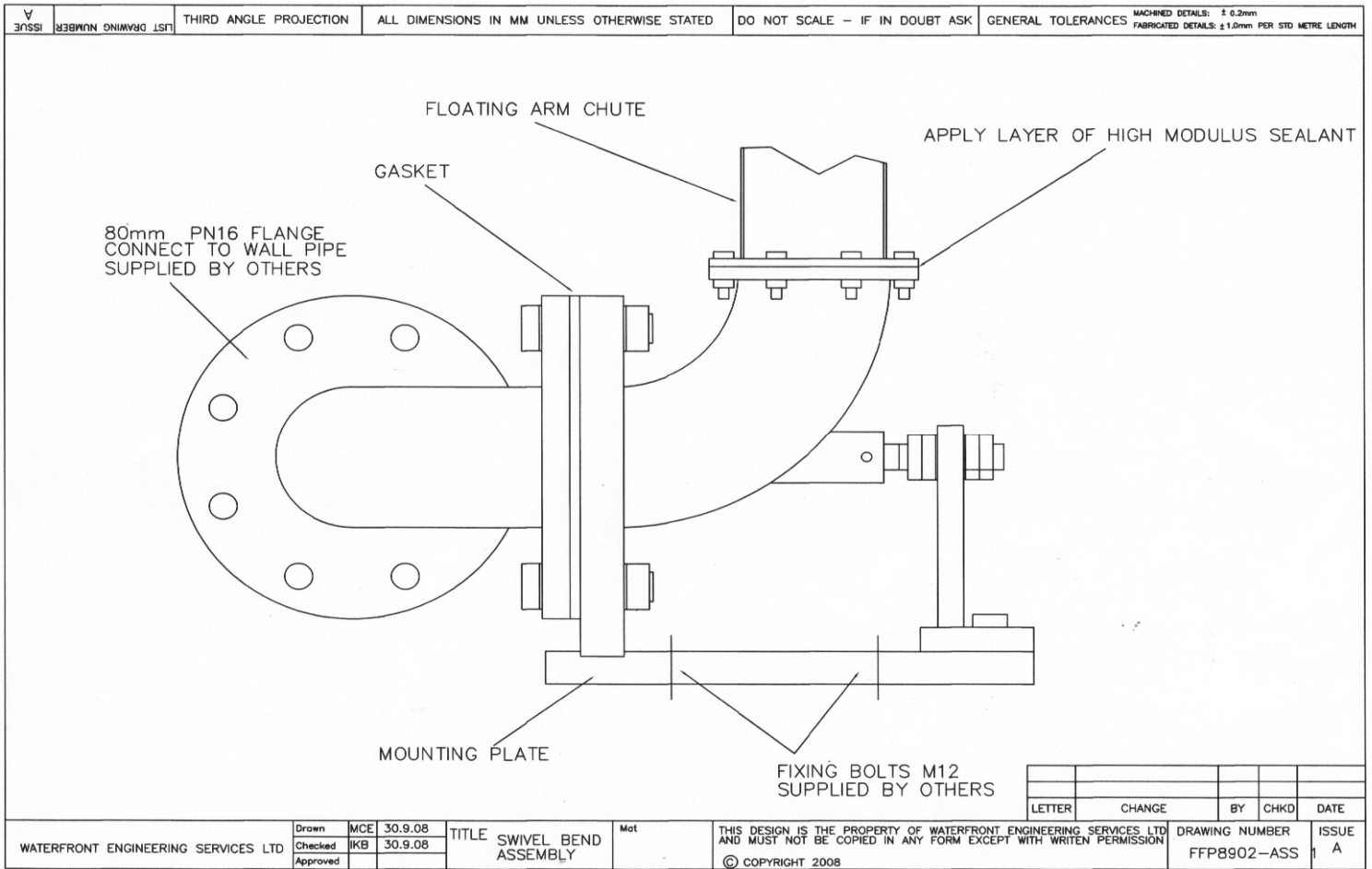

## DRAWING FVS8902-ASS 1

MACHINED DETAILS: ± 0.2mm  
FABRICATED DETAILS: ± 1.0mm PER STD. METRE LENGTH
ISSUE
DRAWING NUMBER
THIRD ANGLE PROJECTION
ALL DIMENSIONS IN MM UNLESS OTHERWISE STATED
DO NOT SCALE - IF IN DOUBT ASK
GENERAL TOLERANCES

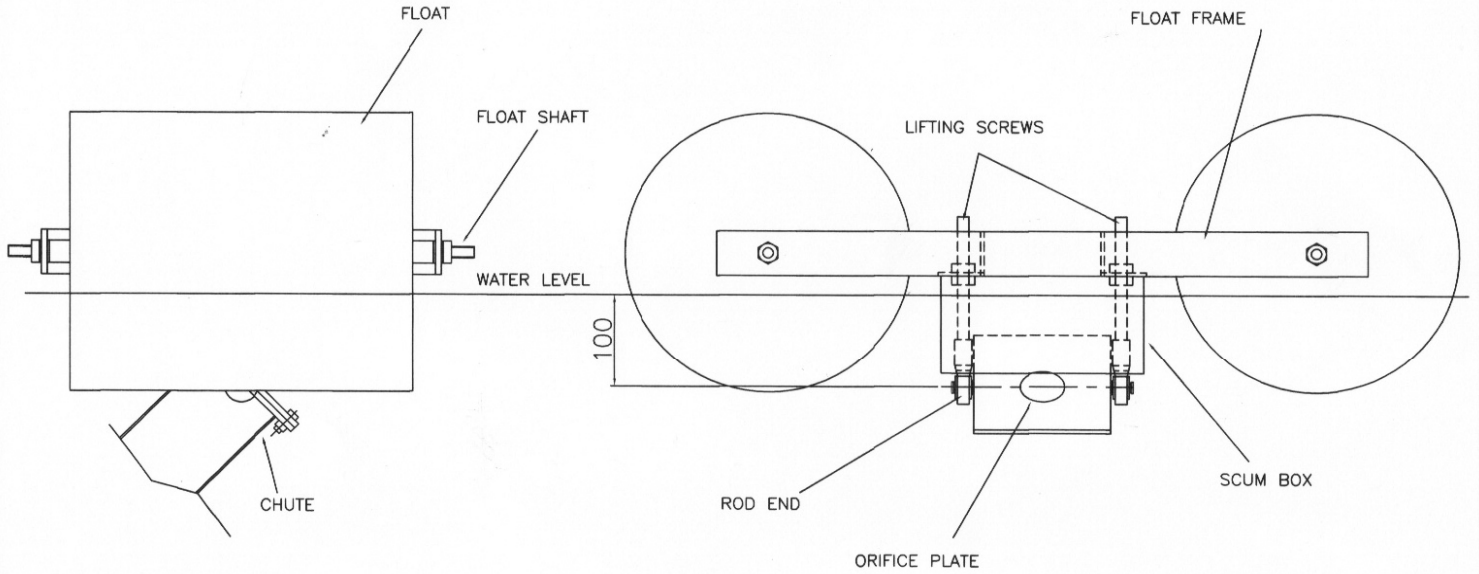

LETTER	CHANGE	BY	CHKD	DATE

WATERFRONT ENGINEERING SERVICES LTD	Drawn	MCE	30.9.08	TITLE FLOAFT CARRIER ASSEMBLY	Mat	THIS DESIGN IS THE PROPERTY OF WATERFRONT ENGINEERING SERVICES LTD AND MUST NOT BE COPIED IN ANY FORM EXCEPT WITH WRITTEN PERMISSION © COPYRIGHT 2008	DRAWING NUMBER FVS8902-ASS 1	ISSUE A
	Checked	IKB	30.9.08					
	Approved							